

INTRODUCTION

The N480D series of PID temperature controllers was designed for non-experienced novice users for combining extreme simplicity in operation with high performance only found in expensive high end controllers.

It is a low-cost instrument which can be easily installed and operated. It accepts most thermocouples and Pt100 RTD, features a relay and pulse output for driving solid state relays and optionally can be supplied with a linear 4 to 20 mA output.

Autotuning PID function, dual display, full range universal power supply and ramps soak function are standard.

It greatly surpasses the old and obsolete analog controllers in performance with ease of operation.



FEATURES

- Accepts thermocouples type J, K, T, R, S, E, N and Pt100 RTD without any hardware change or recalibration.
- Outputs: logic pulse (for driving solid state relays), up to 2 SPST relays and 1 SPDT relay or 4-20 mA output (the SPDT relay and the 4-20 mA output are excludent).
- The outputs have three programmable functions: control, alarm 1 and alarme 2. Obs.: the controller can have up to 4 outputs and in this case 2 outputs will have the same function.
- Alarm functions: LO, HI, differential, differential LO, differential HI, sensor break and end of program.
- Universal switching power supply guarantees high accuracy even under severe mains power oscilations.
- Control output is disabled in case of sensor break or sensor misconnection or malfunction.
- Ramp and Soak: one controlled ramp to soak and one timed soak are standard.
- Autotuning PID parameters.
- Easy-to-set programming menu for non-experienced users.
- Indelible eight-digit electronic serial number can be viewed at the display.
- Keypad is hardware protected avoiding tampering.
- Optional 4-20 mA output.
- Full range 85 to 250 Vac power is standard and 24 V dc/ac is optional.
- Silicone rubber keypad.
- Front panel: IP65, Polycarbonate UL94 V-2.
- Back panel: IP30, ABS+PC UL94 V-0.
- Popular 1/16 DIN size.

SPECIFICATIONS

- Accepts thermocouples type J range -50°C to 760°C, type K range -90°C to 1370°C, type T range -100°C to 400°C, type R range 0 to 1760°C, type S from 0 to 1760°C, type E range -30 a 720°C e type N range -90 a 1300°C with cold junction compensation.
- Accepts 2 or 3-wire Pt100 RTD, range -200°C to 530°C, with cable resistance compensation.
- Pt100 excitantion current: 170 µA.
- Internal A/D resolution: 15,000 levels.
- Displayed resolution: 7,500 levels.
- Four-digit 10 mm red display for measured variable and four-digit 7 mm green display for setpoint.
- Sampling rate: 5 measurements per second.
- Control output update: 200 ms.
- 5 Vdc 20 mA logic control output.
- 1 SPDT relay and 2 SPST 3A @250 Vac relays.
- Power: 85 to 250 Vca, 50/60 Hz; optional 24 Vdc/ac.
- Power consumption: less than 3 VA.
- Operating environment: 0 to 55°C, 20 to 95% RH.
- Panel cutout: 45.5 mm x 45.5 mm.
- Front panel rating: IP65 (NEMA 4X), rear box IP30.
- Weight: 140 g with 1 relay, 160 g with 3 relays.
- Dimensions: 48 x 48 x 110 mm (1.89"x1.89"x4.33").

ELECTRICAL CONNECTIONS

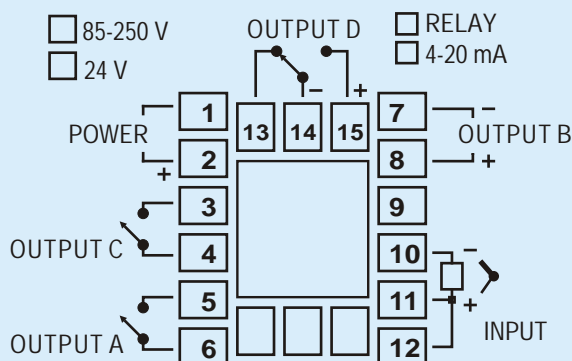

HOW TO ORDER

The basic model accepts several thermocouple types and Pt100 RTD and features one relay and one logic pulse output.

The main control output is user defined via keypad leaving the other output(s) for ON-OFF alarms.

Options: 1 SPDT relay, 1 SPST relay and 4-20 mA output.

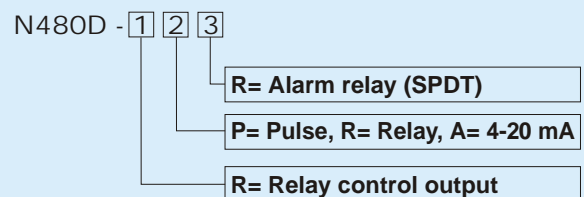

EXEMPLES:

N480D-RP - Basic version. 1 SPST relay + 1 logic pulse output.

N480D-RPR - 1 SPST relay + 1 logic pulse output + 1 SPDT relay.

N480D-RRR - 2 SPST relay + 1 logic pulse output + 1 SPDT relay.