

N1500LC DIGITAL PANEL METER

DIGITAL PANEL METER – INSTRUCTIONS MANUAL – V2.3x K



SAFETY ALERTS

The symbols below are used on the equipment and throughout this document to draw the user's attention to important operational and safety information.

CAUTION: Read this manual carefully prior to installation and operation of the unit.	CAUTION OR DANGER: Electric shock hazard

All safety related instructions that appear in the manual must be observed to ensure personal safety and to prevent damage to either the instrument or the system. If the device is used in a manner not specified in this manual, its safety features may be impaired.

INTRODUCTION

N1500LC is a digital panel meter designed for weighing system with load cells. It accepts a wide variety of electrical signals. It has a display with 6-digit LED display for the measured value and device parameters.

The whole device configuration is done through the keyboard without any change in the circuit. Thus, the selection of input type and the type of alarms action, besides other special functions, are all accessed and programmed through the front keypad.

The main features of the basic version are as follows:

- Input: 4-20 mA, 0-20 mA, 0-50 mV, 0-20 mV, and -20 to 20 mV
- Increasing or decreasing display
- 10 Vdc (or 5 Vdc) power supply for load cells
- Memory for maximum and minimum values
- Hold, Peak Hold, Tare, Zero Tare and Automatic Zero functions
- Digital input

Optionally, it can have:

- Process Variable (PV) retransmission in 0-20 mA or 4-20 mA
- RS485 Modbus RTU serial communication
- 3rd and 4th alarm relays

The front panel is shown below:

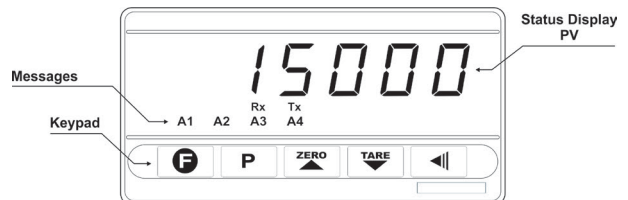

Figure 1 – Identification of the elements of the front panel

Display: Displays the value of the measured variable (PV) and the mnemonics of the device programming parameters.

A1, A2, A3, and A4: Display active alarms.

Rx and Tx: Display RS485 communication line is active.

P key: Key used to access different displays with the programmable parameters of the device.

BACK key: Key used to go back to the previous parameter displayed in the menu display.

INCREMENTS/ZERO key and DECREMENTS/ZERO key: Keys used to change the parameter values. They are also used to display maximum and minimum values stored in memory.

Key Special function: This special function key is used for programmed functions as explained in the [SPECIAL FUNCTION KEY AND DIGITAL INPUT](#) section of this manual.

PROCESS VARIABLE INPUT – PV

The type of input to be used by the digital panel meter must be set via keyboard, among types established in **Table 1**.

All input types available are factory calibrated and require no further adjustment, except the definition of range of indication.

TYPE	CODE	MEASUREMENT RANGE
Non-linear 4-20 mA	c.4-20	Programmable indication range. Three maximum range options: -31000 to +31000 0 to +60000 0 to +120000 (only even values) Non-linear signals will be linearized according to the programmed linearization.
Non-linear 0-20 mA	c.0-20	
Linear 4-20 mA	4-20 R	
Linear 0-20 mA	0-20 R	
Non-linear 0-50 mV	c.50	
Non-linear -20 to 20 mV	c.-20	
Non-linear 0-20 mV	c.20	
Linear 0 – 50 mV	50	
Linear -20 to 20 mV	-20 . 20	
Linear 0-20 mV	20	

Table 1 – Input types accepted by the digital panel meter

ALARMS

The digital panel meter has 2 alarm outputs in the basic version and up to 4 alarms outputs optionally.

Each alarm has a **Warning Light** in the front panel that shows when it was activated.

ALARM FUNCTIONS

The alarms can be set to operate in seven different modes. These modes are shown in **Table 2** and described below.

The alarm can also be set as disabled.

OPEN SENSOR – *iErr*

The alarm is triggered whenever the sensor breaks or is badly connected or broken.

LOW ALARM – *Lo*

Triggered whenever the measured value is **below** the alarm Setpoint.

HIGH ALARM – *Hi*

Triggered whenever the measured value is **above** the alarm Setpoint.

DIFFERENTIAL LOW – *dIFLo*

Triggered whenever the measured value is **below** the point set by:
(**ALrEF** - Deviation)

DIFFERENTIAL HIGH – *dIFHi*

Triggered whenever the measured value is **above** the point set by:
(**ALrEF** + Deviation)

DIFFERENTIAL (OR BAND) OUT OF RANGE – *dIFoU*

For Differential alarm, it is necessary to define two parameters: Differential alarm reference value (**ALrEF**) and Alarm differential Setpoint (Deviation).

The Differential out of range alarm occurs when the measured value is **outside** the range defined by:

(**ALrEF** - Deviation) and (**ALrEF** + Deviation)

DIFFERENTIAL (OR BAND) WITHIN RANGE – *dIFIn*

Same as previous but acting within the range defined above.

TYPE	PROMPT	ACTION
Disabled	oFF	Alarm disabled.
Open sensor (<i>input Error</i>)	iErr	Alarm will go ON if the sensor breaks.
High alarm (<i>Low</i>)	Lo	
High alarm (<i>High</i>)	Hi	
Differential low (<i>Differential Low</i>)	dIFLo	
Differential high (<i>Differential High</i>)	dIFHi	
Differential out of range (<i>Differential Output</i>)	dIFoU	
Differential within range (<i>Differential Input</i>)	dIFIn	

Table 2 – Alarm basic functions

ALARM TIMER

N1500LC allows programming of the Time Setting of Alarms, being able to set delays in alarm condition; send a single pulse at the time of trigger; or allow the generation of sequential pulses.

Table 3 shows these advanced functions. Times T1 and T2 can be programmed from 0 to 6500 seconds and are defined when setting up the device. For alarms with no time delays, set T1 and T2 with value 0 (zero).

The warning LEDs associated with the alarm always light up when the alarm condition occurs, regardless of the status of the output relay, which may be de-energized momentarily due to a time delay.

ADVANCED FUNCTION	T1	T2	ACTION
Normal Operation	0	0	
Delayed	0	1 to 6500 s	
Pulse	1 to 6500 s	0	
Oscillator	1 to 6500 s	1 to 6500 s	

Table 3 – Timer alarm functions

INITIAL BLOCK ALARM

The **Initial Blocking** option inhibits the alarm from being recognized if an alarm condition is present when the controller is first energized.

The alarm will be triggered only after the occurrence of a non-alarm condition followed by a new occurrence for the alarm.

The initial blocking is disabled for the Open Sensor alarm function.

SPECIAL FUNCTIONS

SPECIAL FUNCTION KEY AND DIGITAL INPUT

The key (special function key) as well as the Digital Input may be assigned different functions that will be chosen during the setup. The possible functions are:

ZErO – ZERO FUNCTION

Available only for the key. It resets the scale.

This function is used to eliminate the influence of interference or small deviations in the zero of a scale. Reset is only accomplished if the value shown in the scale is within 2 % of the end of scale.

Zero is not lost if the scale is turned off.

Note: This function can be performed automatically using the parameters **EnR2** and **R2rAn**.

Lo – DISPLAYS MINIMUM

Set the key to, at the first touch, displays the **minimum (Low)** value the digital panel meter measured since the last reset. On the second touch, to show the maximum (High) measured by the digital panel meter since the last reset. On the third touch, the device returns to normal display.

Press the button for more than 5 seconds to reset. This way, the minimum and maximum values will be erased, starting a new cycle.

Hi – DISPLAYS MAXIMUM

Displays the **maximum (High)** value the digital panel meter measured since the last reset.

PHoLd – MAXIMUM VALUE

The digital panel meter will automatically work in the **Peak Hold** mode whenever the **PH** key or the digital input are programmed as **PHoLd**.

This operation mode makes that the digital panel meter always shows the maximum value measured, since the last time the **PH** key or the Digital Input were pressed.

Each activation of the **PH** key or digital input triggers a new **Peak Hold** cycle, resetting the reading of the display to the current value of the measure.

r5t – CLEARS MAXIMUM AND MINIMUM

If configured with **r5t**, each activation of the **PH** key or digital input clear the memory for a new cycle of maximum and minimum values.

HoLd – FREEZE MEASURED VALUE

The **Hold** function freezes the measured value showed in the display. Each time the **PH** key or the Digital Input is selected, there is a change from **Hold** to normal mode.

Whenever the digital panel meter is in the **Hold** mode, the message **HoLd** will be displayed so that the operator will be aware that the value displayed is the frozen value and not the current reading.

tArE – TARE FUNCTION

It is available only in the digital input configuration or through the **TARE** key.

It changes indication to zero (0000.0), regardless of the value applied to the input. It is used to eliminate indications of defined values. To eliminate the tare, you must press the **ZERO** key.

TARE AND ZERO KEYS

The same **Tare** function available for the Digital Input can be quickly applied by using the **TARE** key, which does not need to be set up. The **ZERO** key is used to eliminate the tare applied.

The digital panel meter accepts successive tares, provided that the input signal (gross weight) does not exceed the end of scale.

PROCESS VARIABLE RETRANSMISSION

As an option, the digital panel meter can be supplied with an isolated 0-20 mA or 4-20 mA analog output for Process Variable (PV) retransmission. Available at terminals 29 and 30 of the rear panel of the device.

When this option is available, the retransmission is always enabled and does not require any intervention.

The PV values that define the scale of the 0 mA / 4 mA to 20 mA retransmission can be programmed in the **high and low output limits (O_uL_oL and O_uH_oL)** at the Configuration Cycle. These limits can be defined freely, and you can make a retransmission with increasing or decreasing behavior toward to the indicated value.

For a voltage output signal, an external shunt (calibrated resistor) should be installed at the analog output terminals.

LOAD CELL POWER SUPPLY (AUXILIARY P. S.)

The digital panel meter provides a voltage power supply of 10 Vdc to excite field transmitters with 35 mA current capacity.

Available at the back panel terminals 16 and 17.

CUSTOMIZED LINEARIZATION

The digital panel meter has five types of input for non-linear signals:

c.4-20, c.0-20, c.50, c.-20 and c.20

For using these signals, is necessary to adopt the **Custom Linearization** option. This feature combines the input signal to 30 user-defined line segments; setting two points for each segment, a

start and end and the respective display values. Thus, the indication will have a non-linear behavior set by the input signal.

The following figure shows an input signal associated with four-line segments (a, b, c, and d), causing that the resulting indication can be approximated to the ideal value (characteristic curve). The resulting indication is as best as the best straight segments are chosen.

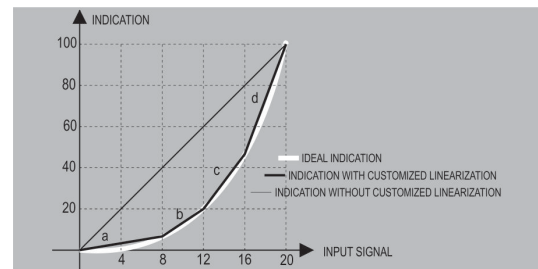

Figure 2 – Custom linearization for a nonlinear signal

Note: The non-linear input signal shall have increasing pattern.

CONFIGURATION PROTECTION

As a safety measure, parameter changes can be prevented through a key combination performed at each level. With this protection, the parameters are still displayed but cannot be changed.

To protect any level, just go to the level and press the **ZERO** and **TARE** keys simultaneously for 3 seconds.

To unlock the level, press the **TARE** and **TARE** keys for 3 seconds.

The display will flash briefly to confirm locking or unlocking level.

Inside the controller, the **PROT** key complements the protection function. In the **OFF** position, you can do and undo the protection of cycles. In the **ON** position, you cannot make changes. If there are protections cycles, these cannot be removed; if there is not, they cannot be promoted.

INSTALLATION

The digital panel meter is designed to be panel mounted. Remove the two plastic fixing clamps from the instrument, insert the device into the panel cut-out and slide firmly the fixing clamps from the rear against the panel.

INSTALLATION RECOMMENDATIONS

- The wires of the input signals must be installed separated from the output wires and power. If possible, in grounded conduits.
- The power supply for the instruments must be provided from an exclusive power source.
- In controlling and monitoring applications, possible consequences of any system failure must be considered in advance. The internal alarm relay does not warrant total protection.
- Use of RC FILTERS (47 R and 100 nF, serial) are highly recommended when driving solenoids, contactor coils or other inductive loads.

ELECTRICAL CONNECTIONS

The whole inner part can be removed without the need to make any disconnection.

Figure 3 shows the connection arrangement at the rear panel of the digital panel meter:

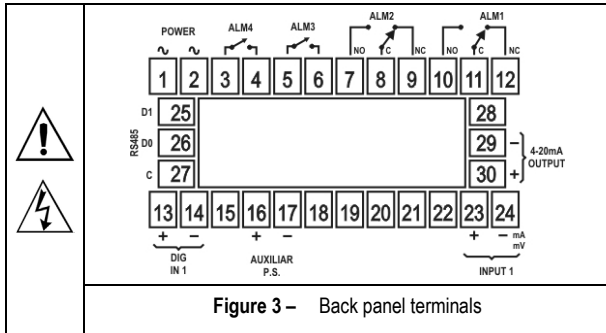

POWER CONNECTION

First check if the voltage required by the digital panel meter is compatible with the voltage of instrument power supply. Provide adequate protection devices.

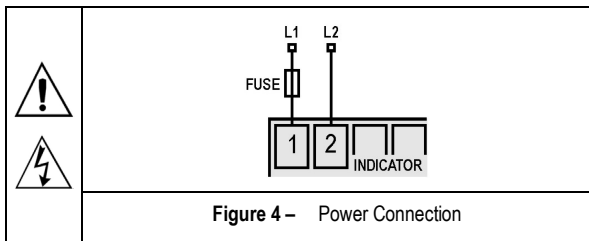

INPUT SIGNAL CONNECTION

It is important that they are very well connected, the sensor wires must be well fixed in the terminals of the rear panel.

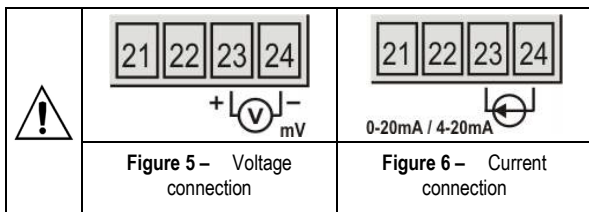

LOAD CELL CONNECTION USING THE POWER SUPPLY

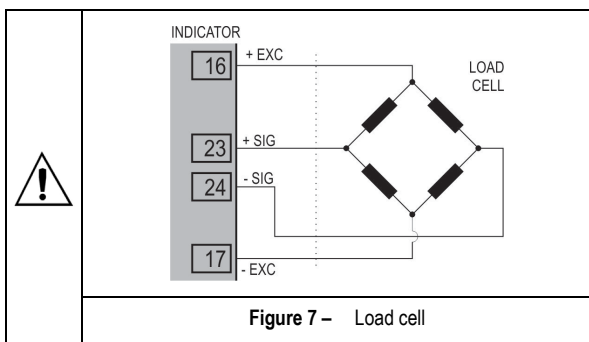

DIGITAL INPUT (DIG IN)

To use the Digital Input, a switch must be connected to respective terminals (dry contact), as shown in **Figure 8**:

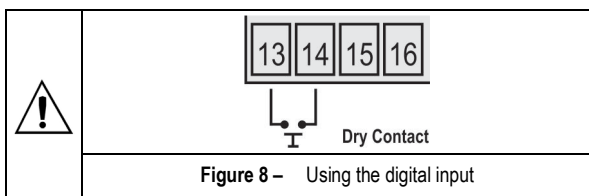

ANALOG OUTPUT (4-20 MA OUTPUT)

The analog output may be 0-20 mA or 4-20 mA, selected in the configuration.

The output is available at terminals 29 and 30, as requested in the purchase order.

OPERATION

For best results, this digital panel meter requires correct basic setting of parameters or a definition for parameters displayed. It is necessary to define, for example: Input type (0-20 mA, 4-20 mA, etc.), range display, alarm set point, alarm function etc.

To make configuration easier, the parameters are divided in five cycles (or groups):

CYCLE	ACCESS
1 – Work	Free access
2 – Alarms	Reserved access
3 – Special functions	
4 – Input setting	
5 – Customized linearization	
6 – Calibration	
7 – Automatic calibration	

Table 4 – Parameters cycles

The work cycle has free access. All other cycles require a certain combination of keystrokes to be accessed. The combination is:

P and **◀** keys pressed simultaneously

Once within a cycle, just press **P** to move to the subsequent parameters of this cycle. At the end of each cycle the display will go back to the work cycle.

At the desired parameter, just press the buttons **▲** or **▼** to promote the desired changes. These changes are saved into protected memory and given as valid when we move to the next parameter.

After 25 seconds with no key pressed the digital panel meter will return to the Measurement screen at work cycle.

Note: It is recommended to disable/suspend the control whenever it is necessary to change the device settings.

PROGRAMMING THE DIGITAL PANEL METER

WORK CYCLE

This is the first cycle. At power up, the digital panel meter will display the Process Variable (PV). The alarm triggering points are also displayed at this cycle (alarm Setpoints).

To advance in this cycle, simply press **P** key.

SCREEN	PARAMETER DESCRIPTION
BBBBB.	Screen measures. Shows the variable measured according to the limits defined in the inLoL and inHiL screens. Should any failure occur, the digital panel meter will display an error message.
ALREF	Differential alarm reference value. This screen is shown only when there is an alarm programmed with differential function. This value is used as a reference for differential alarms triggering.
SPAL 1 SPAL 2 SPAL 3 SPAL 4	Alarms SPs 1, 2, 3 and 4. Defines the operation point of each alarm programmed with Lo or Hi functions. For alarms programmed with differential functions, the alarm SP value cannot be changed, and the dIF message is displayed.

	<p>The value of differential SP (deviation) is defined in the Alarms Cycle.</p> <p>Note: The SP adjustment parameters are presented only if the corresponding alarm function is configured.</p>
--	--

ALARM CYCLE

F_wAL 1	Alarm function.
F_wAL 2	Defines the alarm functions: 1, 2, 3 or 4, configured in ALARM FUNCTIONS section.
F_wAL 3	
F_wAL 4	<p>oFF Alarm off</p> <p>!Err Broken or Shorted Sensor</p> <p>Lo Low value</p> <p>Hi High value</p> <p>dIFLo Differential low</p> <p>dIFHi Differential high</p> <p>dIFoU Differential outside the range</p> <p>dIFIn Differential within range</p>
HYAL 1	Alarm hysteresis.
HYAL 2	Defines the difference between the value at which the alarm is turned on and the value at which it is turned off.
HYAL 3	
HYAL 4	
bLAL 1	Initial Blocking Function.
bLAL 2	It makes possible to prevent alarms activation at the process start when all the system is powered.
bLAL 3	
bLAL 4	
ALt 1	Alarm Timer Function.
ALt 2	Screens that define time T1 and T2, in seconds, shown in Table 3 .
AL2t 1	
AL2t 2	They allow to delay the alarm triggering, to activate alarms momentarily or sequentially.
AL3t 1	
AL3t 2	To disable timer function, just set zero for T1 and T2.
AL4t 1	
AL4t 2	

FUNCTION CYCLE

FFunc	<p>F key function.</p> <p>Makes possible to define the F key function. Available functions:</p> <p>oFF Key not used</p> <p>HoLd Hold PV</p> <p>rSt Resets maximum and minimum values</p> <p>PHoLd Peak Hold</p> <p>Hi Displays maximum</p> <p>Lo Displays minimum</p> <p>ZEro Automatic zero</p> <p>These functions are described in detail in the SPECIAL FUNCTION KEY AND DIGITAL INPUT section.</p>
dIGIn	<p>Digital input function.</p> <p>Makes possible to define the digital input function. Functions available are the same as the ones available for the F key, except for the Zero function, replaced by the Tare function.</p> <p>oFF - HoLd - rSt - PHoL - Hi - Lo - tArE</p> <p>These functions are described in detail in the</p>

	SPECIAL FUNCTION KEY AND DIGITAL INPUT section.
FILtR	<p>Input digital filter.</p> <p>Used to reduce the noise in the measured value.</p> <p>Adjustable from 0 to 60. 0 means the filter is off and 60 means maximum filtering. The filter slows down the response of the measured value.</p>
oFSEt	<p>Displayed offset.</p> <p>Added value to the measured value to correct the Offset. Expressed in the unit configured input type.</p>
EnAZ	<p>Enables Auto Zero.</p> <p>Enables the Auto Zero function of the indication. The indication will turn to zero if the input value is within the programmed range in ARAn for 3 seconds.</p> <p>Auto Zero occurs when the indication is relatively stable. It is used to eliminate the influence of interference or small deviations in the zero of a scale.</p>
ARAn	<p>Maximum level for zero.</p> <p>Maximum level of the scale zero deviation, where auto-zero is activated. This value can be programmed up to 2 % of the end of scale.</p>
bAud	<p>Communication Baud Rate.</p> <p>Transmission Baud Rate used in serial communication (RS485) in bps and kbps.</p> <p>1200, 2400, 4800, 9600, 19200, 38400, 57600, 115.2. (NONE parity) 1.2P, 2.4P, 4.8P, 9.6P, 19.2P, 38.4P, 57.6P and 115.2P (with EVEN parity).</p>
AdRES	<p>Communication address.</p> <p>A number that identifies the device in a communication network.</p>

CONFIGURATION CYCLE

IntYP	<p>Input type.</p> <p>Selects the input signal or sensor type to be connected to the PV terminals.</p> <p>Changing the input type causes all other parameters related to PV and alarms to be changed as well.</p> <p>This parameter shall be the first to be set.</p>
dPPoS	<p>Decimal point position.</p> <p>Determines the position of the decimal point in the display.</p>
ScALE	<p>Parameter that defines the indication limits of the inputs.</p> <p>0 Configurable indication from - 31000 to + 31000.</p> <p>1 Configurable indication from 0 to + 60000.</p> <p>2 Configurable indication from 0 to +120000, showing only even values.</p> <p>The PV values, SP Alarms and Offset also obey these limits.</p>
inLoL	<p>Input low limit.</p> <p>Determines the minimum limit for input signals. The range created can be ascending or descending in relation to the input signal behavior.</p>
inHiL	<p>Input high limit.</p> <p>Determines the maximum limit for input signals. The range created can be ascending or descending in relation to the input signal behavior.</p>
outtY	<p>Analog output type.</p> <p>Allows selecting the signal type available on the analog output: 0-20 mA or 4-20 mA.</p>

ouLoL Output Low Limit	Low limit for analog retransmission. Determines the display value corresponding to an electric current of 4 mA (or 0 mA).
ouHiL Output High Limit	High limit for analog retransmission. Defines the PV value that results in a 20 mA analog output current.
outEr Output error	Error signaling for 4-20 mA output. Configure the status of the analog output when an error occurs in the retransmission (beginning or end of the scale).

CUSTOMIZED LINEARIZATION CYCLE

inPD1 inP.30	Defines the extreme points of the customized linearization. Values must be in the input signal unit.
outD1 out.30	Defines the proportional indications in respect to each segment of the customized linearization. Values are in the intended indication unit.

CALIBRATION CYCLE

All input and output types are factory calibrated. We recommend not making any calibration procedure. This cycle should only be accessed by experienced personnel.

If this cycle is accidentally accessed, do not touch the **MIN** or **MAX** keys. Go through all the screens until you return to Operating Cycle (operation).

inLoC	Zero input calibration. It allows you to calibrate the offset of PV. You can increment or decrement the desired value by pressing the ZERO and TARE keys.
inHiC	Span input calibration. Sets the PV gain.
ouLoC	Zero calibration for the analog output. Value for the analog output Offset (0 or 4 mA).
ouHiC	Analog output Span calibration. Value for gain calibration of the analog output (20 mA).

HtYPE	Hardware type. Parameter to adjust the digital panel meter to the type of available hardware. Should not be changed, except when a new accessory is inserted or removed. 2 Alarms Code 3 2 Alarms and 4-20 mA Code 19 2 Alarms and RS485 Code 35 2 Alarms and 4-20 mA and RS485 .. Code 51 4 Alarms Code 15 4 Alarms and 4-20 mA Code 31 4 Alarms and RS485 Code 47 4 Alarms and 4-20 mA and RS485 .. Code 63
--------------	--

AUTOMATIC CALIBRATION CYCLE

Specific calibration for weighing systems, where the user himself performs the calibration of their system, using two reference weights, minimum and maximum, and setting their indication values.

To access this cycle, press and keep pressed **P** and **◀** for 30 seconds.

ACALL	Minimum weight automatic calibration. This parameter defines the value to be displayed when the minimum reference weight is applied. See the PERFORMING AUTOMATIC CALIBRATION section.
ACALH	Maximum weight automatic calibration. This parameter defines the value to be displayed when the maximum reference weight is applied. See the PERFORMING AUTOMATIC CALIBRATION section.

Table 5 shows the sequence of cycles and parameters presented in the display. There are parameters that must be defined for each alarm available.

WORK CYCLE	ALARM CYCLE	FUNCTION CYCLE	CONFIGURATION CYCLE	CUSTOMIZED LINEARIZATION CYCLE	CALIBRATION CYCLE	AUTOMATIC CALIBRATION CYCLE
BBBBB	* FuRL1	FFunC	intYP	inPD1 - inP.30	inLoC	ACALL
RLREF	* HYRL1	dIG.in	dPPoS	outD1 - out.30	inHiC	ACALH
* SPAL1	* bLRL1	FILtr	ScALE		ouLoC	
	* RLIt1	oFSEt	inLoL		ouHiC	
	* RLIt2	EnR2	inHiL		HtYPE	
		R2 rAn	outtY			
		bAud	ouLoL			
		AdrES	ouHiL			
			outEr			

Table 5 – Sequence of cycles and parameters displayed by the digital panel meter

* Parameters that require definition for each available alarm.

CONFIGURATOR SOFTWARE

Available for free download from the **NOVUS** website, **QuickTune** software is the ideal tool to configure the **N1500**. It also has diagnostic tools.

To configure the device, simply follow the procedure below:

1. Download and install the software on the computer to be used.
2. Run **QuickTune**, set up communication and start device recognition.

PROBLEMS WITH THE DIGITAL PANEL METER

Connection errors or improper configuration will result in malfunctioning. A final review can avoid wasting time and losses.

Some error messages will help to identify possible problems.

MESSAGE	PROBLEM DESCRIPTION
UUUUU	Measured value is above the value allowed for the selected sensor or signal limit.
nnnnn	Measured value is below the value allowed for the selected sensor or signal limit.
-----	Open input. No signal.

Table 6 – Error messages

Other error messages shown by the digital panel meter must be reported to the manufacturer. Inform the serial number if this should occur. The serial number can be viewed at the display by pressing the  key for about 3 seconds.

The software version of the device can be viewed at the time it is powered.

When not properly configured, the device may show false error messages, particularly those related to the input type selected.

SPECIAL RECOMMENDATIONS





Should the digital panel meter be repaired, some special handling should be taken.

The device must be withdrawn from the housing and immediately placed in an anti-static wrap; protected from excessive heat and humidity.

INPUT CALIBRATION



When recalibration of some type of input is required, proceed as described below.

You must use an appropriate framework for calibration, with equipment capable to provide the proper electrical signals.

- a) Set the digital panel meter for the input type to be calibrated (See **Table 1**).
- b) Program the desired upper and lower display limits (**InLoL** and **InHiIL**) with limits on the type of configured input (See **Table 1**).
- c) Access the **InLoL** parameter and applied to input a signal corresponding to a known value and slightly above of the lower limit.
- d) Set the indicated value using the  and  keys to adjust the expected value for the applied signal.
- e) Access the **InHiIL** parameter and applied to input a signal corresponding to a known value and slightly below of the upper limit.
- f) Set the indicated value using the  and  keys to adjust the expected value for the applied signal.
- g) Exit the Calibration Cycle and verify that the calibration became adequate. Repeat **c** to **f** until no new adjustment is necessary.

PERFORMING AUTOMATIC CALIBRATION

To perform automatic calibration, the system must already be installed and configured with the input type and range already defined.

- a) Access the Auto Calibration Cycle and the **ACALL** parameter.
- b) Put on the load cell the minimum reference weight and wait to stabilize.
- c) Adjust the **ACALL** parameter to display the desired value.
- d) Press the  key to save this value and advance to the parameter **ACALH** parameter.
- e) Put on the load cell the maximum reference weight and wait to stabilize.
- f) Adjust the parameter **ACALH** to display the desired value.
- g) Press  key to save this value and terminate the procedure. At this time, the digital panel meter will show the weight on the load cell.

SERIAL COMMUNICATION

The digital panel meter can be supplied with an asynchronous RS485 digital communication interface for master-slave connection to a host computer (master). The digital panel meter always works as a slave.

Communication is always initiated by the master, which sends a command to the slave address with which to communicate. The addressed slave takes over the line and sends the requested reply.

The digital panel meter accepts broadcast commands (addressed to all instruments of the network). In this type of command, the digital panel meter does not send any response

N1500LC uses signals compatible with the RS485 standard allows 2-wire connection with a master and up to 31 digital panel meters (and can address up to 247) with bus topology.

Maximum connection distance: 1000 meters.

Digital panel meter off time: Maximum 2 ms after the last byte.

Communication signals are electrically isolated from the rest of the device, with selectable Baud Rate between 1200, 2400, 4800, 9600, 19200, 38400, 57600, and 115600 bps.

- Number of data bits: 8 with no parity or even parity.
- Number of stop bits: 1
- Response start time: Maximum 100 ms after receiving the command.
- Protocol: MODBUS (RTU)

Signals from the RS485 interface are:

D1	D	D +	B	Bidirectional data line.	Terminal 25
D0	\bar{D}	D -	A	Inverted bidirectional data line.	Terminal 26
C				Optional connection. Improves communication performance.	Terminal 27
GND					

Table 7 – RS485

In case the host computer does not have an RS485 interface integrated, shall be used an external RS232 ↔ RS485 converter.

Two parameters must be configured to use the serial communication interface: Communication Baud Rate (**bAud** parameter) and Communication Address (**AdRES** parameter).

SPECIFICATIONS

DIMENSIONS: 48 x 96 x 92 mm (1/8 DIN)

Approximate weight: 250 g

PANEL CUT-OUT: 45 x 93 mm (+0.5 -0.0 mm)

POWER: 100 to 240 Vac/dc ($\pm 10\%$), 50/60 Hz

Optional 24 V: 12 to 24 Vcc / 24 Vca (-10% / $+20\%$)

Max. consumption: 7.5 VA

ENVIRONMENTAL CONDITIONS:

Operating temperature: 5 to 50 °C

Maximum RH: 80 % up to 30 °C

For temperatures above 30 °C, decrease 3 % per °C

For indoor use; Installation category II, pollution degree 2; altitude < 2000 m

INPUT Voltage and Current; configurable according to **Table 1**

Internal resolution: 128000 levels

Display resolution: 62000 levels

Input sample rate: 15 samples per second

Accuracy: 0.2 % of span.

Input impedance: 0-50 mV >10 M Ω

..... 0-20 mA, 4-20 mA: 15 Ω (+2 Vdc @ 20 mA)

ANALOG OUTPUT: 0-20 mA or 4-20 mA, 550 Ω max.

4000 levels, isolated, for control or retransmission of PV and SP

RELAY OUTPUT: ALM1 and ALM2: SPDT: 3 A / 240 Vac (3 A / 30 Vdc Res.)

ALM3 and ALM4: SPST-NO: 1.5 A / 250 Vac (3 A / 30 Vdc Res.)

AUXILIARY VOLTAGE SUPPLY: 5 or 10 Vdc, $\pm 1\%$, 35 mA

EMC: EN61326-1:1997 and EN61326-1/A1:1998

SAFETY: EN61010-1:1993 and EN61010-1/A2:1995

CONNECTIONS SUITABLE FOR TERMINAL TYPE FORK 6.3 MM

FRONT PANEL: IP65, polycarbonate UL94 V-2

HOUSING: IP20, ABS + PC UL94 V-0

STARTS OPERATION: 3 seconds after power-up.

CERTIFICATIONS:   

IDENTIFICATION

N1500LC -	4R -	RT -	485 -	24V
A	B	C	D	E

A: Model **N1500LC** – Version dedicated for load cells

B: Relays outputs **blank** (2 relays) or **4R** (4 relays)

C: Analog output **RT** – (PV retransmission in mA) or **blank**

D: Digital Communication **485** – (RS485, Modbus protocol) or **blank**

E: Power Supply **blank** (100-240 Vac/dc) or **24V** (24 Vdc/ac)

WARRANTY

Warranty conditions are available on our website www.thermoest.com